

# TSW-1050-FMKT

## TSW-1050 Flush Mount Kit

The TSW-1050-FMKT flush mount kit is an optional accessory for use with a Crestron® TSW-1050 10.1" touch screen. It is designed for a flush installation of a TSW-1050 touch screen onto a concrete/brick wall and drywall. The TSW-1050-FMKT securely mounts the touch screen while allowing easy access, insertion and removal by manual push and magnet detachment of the touch screen tray.

When installing the TSW-1050-FMKT onto a concrete/brick wall first install the TSW-1050-FMKT-BBI brick wall back box for a professional installation. The TSW-1050-FMKT is configured for installation in a 12.7 mm (1/2 inch) thick clad constructions, shimming may be required if adjacent material is not 12.7 mm drywall (1/2 inch). Installation and finishes are in the same manner as drywall.

- > Flush with wall
- > Paintable with wall paint in any color and texture
- > Allows easy insertion and removal of the keypad by manual push and magnet detachment of the touch screen tray.
- > The adapter is supplied unpainted (to be painted after installation as part of the wall)
- > Installation of the flush mount adapter is straight-forward.
- > Installation process is similar to drywall construction procedures
- > Designed for the use with TSW-1050 touch screen

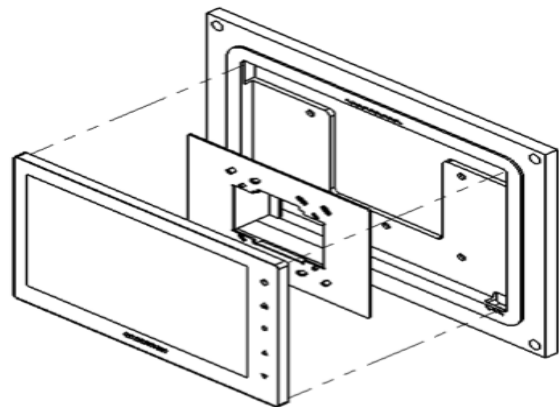

## SPECIFICATIONS

### Material

Construction : MDF

### Dimensions

Height: 234.7 mm (9.2 inch)

Width: 327.7 mm (12.9 inch)

Depth: 16.6 mm (0.65 inch)

### Weight

0.54 kg (1.2 pounds)