

MonLines MWH015B Height-adjustable LCD TV wall mount 37" - 60"

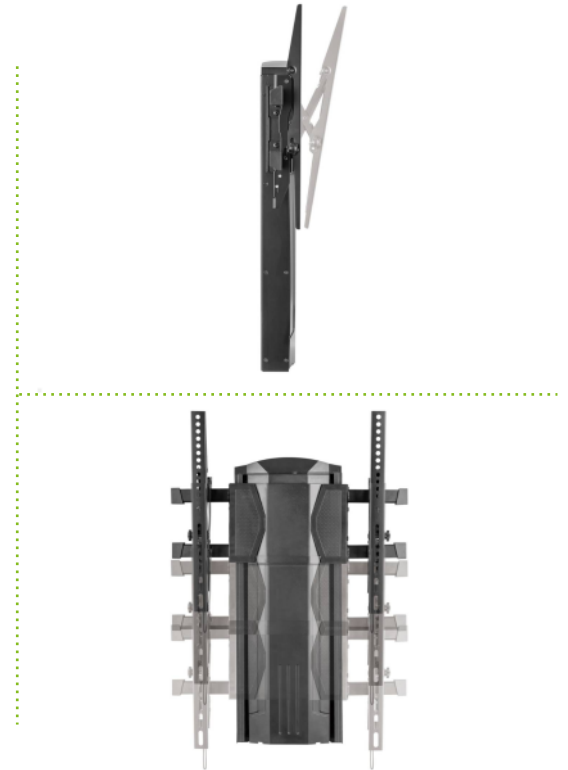

Description

The MonLines MWH015B height adjustable TV wall bracket mounts up LCD TVs / screens to the desired height. With the integrated spring system a stepless vertical alignment of the screen up to max. 400 mm is possible. The height-adjustable TV wall mount allows the installation of OLED, LED, LCD and plasma TVs and a maximum of individuality. The display can be positioned at any height. The LCD TV wall mount is equipped with a VESA compliant hole patterns standard from 200x200 to 600x400 mm for mounting different TV manufacturers and sizes. The TV can be tilted up to 10° to avoid a disturbing glare effect. The combination of functionality and innovation characterises this MonLines wall mount.

Key features

Screen sizes:	37" to 60"
VESA standard:	200x200, 200x300, 200x400, 300x200, 300x300, 400x200, 400x300, 400x400, 400x600, 400x800, 500x400, 500x500, 600x200, 600x300, 600x400 mm
Load capacity:	7 - 20 kg
Wall distance:	85 mm
Mobility:	Height adjustable up to 400 mm / tilt -10°
Mounting type:	Wall bracket with spring system
Net weight:	15 kg
Finish:	Black