



PUC 2115
150 cm pole

Specifications

- Max. weight: 30 kg / 66 lbs
- Guarantee: 5 years
- Available colours: Silver/Aluminium

The PUC 2115 is a 150 cm pole and is a part of the modular Connect-it system with which you can create your own ceiling solution for small- to medium-sized displays.



PUC 2115 150 cm pole

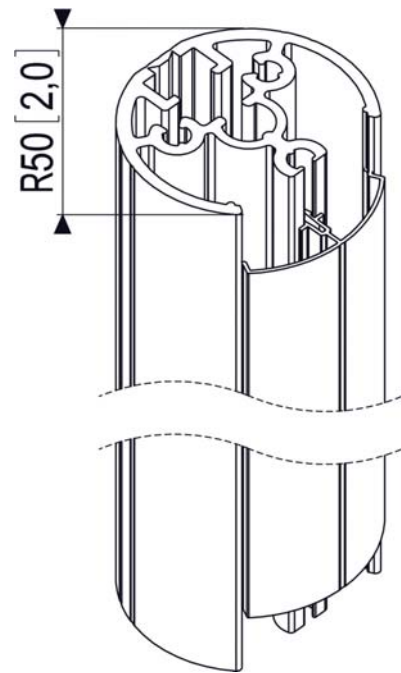

The PUC 2115 is equipped with a double CIS® cable duct system with which you can quickly and simply ensure that all cables are concealed. The pole is made of aluminium and, therefore, it can be easily cut at the required length. Therefore, combine a pole with one of the Connect-it ceiling plates (PUC 1010, PUC 1030 or PUC 1040) or the truss adapter (PUC 1050) and a Connect-it interface (PFI 3010, PFI 3020 or PFI 3030) for a complete ceiling solution.

Features

- Stylish design
- Aluminium, easy to cut to length
- CIS® Cable Inlay System
- Easy mounting

Logistic information

- Packaging size: 102x1540x78 mm
- Max. weight: 3 kg / 7 lbs
- EAN Code: 8712285317163